



(12) **EUROPEAN PATENT SPECIFICATION**

(45) Date of publication and mention of the grant of the patent:
16.12.1998 Bulletin 1998/51

(51) Int Cl. G06K 19/16

(21) Application number: 92101231.6

(22) Date of filing: 27.01.1992

(54) **Transparent optical identification label**
Transparentes optisches Kennzeichen
Plaque d'identification optique transparent

(84) Designated Contracting States:
DE FR GB

(30) Priority: 11.09.1991 JP 259636/91

(43) Date of publication of application:
17.03.1993 Bulletin 1993/11

(73) Proprietor: NHK SPRING CO.LTD.
Yokohama-shi, Kanagawa-ken (JP)

(72) Inventors:
• Hoshino, Hidekazu
Kanazawa-ku Yokohama-shi Kanagawa-ken (JP)

• Takeuchi, Itsuo
Kanazawa-ku Yokohama-shi Kanagawa-ken (JP)

(74) Representative: Orr, William McLean
URQUHART-DYKES & LORD
5th Floor, Tower House
Merrion Way
Leeds West Yorkshire, LS2 8PA (GB)

(56) References cited:
EP-A- 0 304 194 FR-A- 2 515 396
GB-A- 2 212 445 US-A- 4 140 373
US-A- 4 171 864

EP 0 531 605 B1

Note: Within nine months from the publication of the mention of the grant of the European patent, any person may give notice to the European Patent Office of opposition to the European patent granted. Notice of opposition shall be filed in a written reasoned statement. It shall not be deemed to have been filed until the opposition fee has been paid. (Art. 99(1) European Patent Convention).

Description

TECHNICAL FIELD

The present invention relates to an optical identification label which is transparent to human eyes but has a specific optical property which can be identified with optical means.

BACKGROUND OF THE INVENTION

Conventionally is known the structure in which a hologram which is difficult to duplicate is affixed as an identification label to objects such as magnetic cards and other information storage cards, stocks and bonds, tickets, and other commercial goods to identify their authenticity, and such a label is disclosed, for instance, in Japanese utility model laid-open publication (kokai) No. 61-182580 or in GB-A-2 212 445.

However, such an identification label is necessarily affixed to a location which can be readily and visually identified because it is required to be visually identified. Therefore, the freedom of the design of the object tends to be reduced because the position, shape and color of the identification label must be considered as a part of the design, and the external appearance of the object may be seriously impaired because of the failure to achieve an acceptable design balance.

According to the disclosure of Japanese patent laid-open publication (kokai) No. 3-71383 by the applicant of this patent application, a hologram area having a unique diffraction property is provided on the surface of an object, and this hologram area is identified with an identification unit serving as optical identification means. By using this structure, since the object consists of an object having a fixed shape, such as information storage cards, stocks and bonds, and tickets, and the identification process is carried out by the identification unit, it is possible to place an identification label at an inconspicuous location on the object and to improve the freedom in the design of the object, but the very existence of the identification label on the surface of the object could not totally eliminate the restriction on the design of the object.

Meanwhile, as for the system in which the identification process is carried out with a machine, since the operator is not required to heed the location at which the identification label is placed, it is preferable to make the visual recognition of the existence of the identification label difficult as much as possible to the end of discouraging any attempt to duplicate the identification label with an fraudulent intent.

BRIEF SUMMARY OF THE INVENTION

In view of such problems of the prior art, a primary object of the present invention is to provide an optical identification label which would not affect the external

appearance of the object to which the label is affixed.

A second object of the present invention is to provide an optical identification label which is difficult to fabricate for potential forgers.

A third object of the present invention is to provide an optical identification label which ensures accurate and reliable identification.

These and other objects of the present invention are accomplished by the transparent optical identification label according to claim 1. This label comprises a reflective layer which transmits visible light but reflects light of other wavelengths with a specific directivity that can be identified with optical identifying means. Such a reflective directivity is produced by using hologram or diffraction grating.

Also, such a wavelength selectivity may be produced in the reflective layer by alternately laminating layers of two or more kinds of different materials having different refractive indices to form the reflective layer.

The identification label of the present invention may be conveniently used as means for preventing an unauthorized duplication of an object to which the identification label is affixed. Further, data may be encoded in the geometrical pattern of the reflected light so that the identification label may be used as an information carrier.

According to such a structure, since visible light is not reflected by the light reflecting layer or, in other words, the light reflecting layer is transparent to human eyes, the identification label would not affect the design of the object in any way. Since the position of the identification label cannot be easily visually determined, forgery of the identification label is rendered highly difficult.

BRIEF DESCRIPTION OF THE DRAWINGS

Now the present invention is described in the following with reference to the appended drawings, in which:

Figure 1 is a perspective view of a card, and an essential part of the structure for identifying the authenticity of the card;

Figure 2 is a plan view of a light emitting device and a light receiving device;

Figure 3 is an enlarged sectional view of the identification label; and

Figure 4 is a graph showing the relationship between the wavelength of the illuminating light and the transmittance of the light reflecting layer.

DETAILED DESCRIPTION OF THE PREFERRED EMBODIMENT

Figures 1 through 5 show an embodiment of the present invention applied to a magnetic card given here as an example of information storage card. Referring to Figure 1, a magnetic stripe 2 extends longitudinally on a surface 1a of the card 1. The surface 1a is also pro-

vided with an identification label 3 serving as a light reflecting part and having a hologram layer given with a specific reflective directivity as described hereinafter.

Meanwhile, a magnetic head 4 is provided in a reader/writer of the card 1 which opposes the magnetic stripe 2 when the card 1 is conveyed by a conveyer unit not shown in the drawings. Also provided is a light emitting/receiving unit 5 so as to oppose the identification label 3 when the card 1 is conveyed. This light emitting/receiving unit 5 consists of a light emitting device 6 for projecting an illuminating laser light beam upon the identification label 3 on the surface 1a of the card 1, and an annular light receiving device 8 surrounding the light emitting device 6 as illustrated in Figure 2. The light emitting device 6 directly opposes the identification label 3 when the card 1 is at a certain prescribed position. The light receiving device 8 consists of a multi-section photodiode which is divided into eight sectors 8a through 8h which can individually detect light. This light receiving device 8 is connected to a determination unit 9 which consists of known CPU, memory, I/F and other components for determining the authenticity of the card 1.

As best illustrated in Figure 3, the identification label 3 comprises a hologram layer 10 consisting of a hologram forming layer 10a and a light reflecting layer 10b disposed under the hologram forming layer 10a, a bonding agent layer 11 for integrally retaining the hologram layer 10 and securely attaching it to the surface 1a of the card 1, and a protective layer 12 covering the outer surface of the hologram layer 10.

Here, it should be noted that the hologram forming layer 10a is a transparent layer. As shown in Table 1, the light reflecting layer 10b is formed by alternately laminating layers of sodium hexafluoro-aluminate (Na_3AlF_6) having a relatively small index of refraction and layers of zinc sulphate (ZnS) having a relatively large index of refraction, and, as shown in Figure 4, has a transmittance of approximately 100% in the range of visible light (380 nm to 700 nm in wavelength) and a transmittance of approximately 0% in the range of infrared light (780 nm or longer in wavelength).

Table 1

Layer Number	material	thickness (nm)
1	Na_3AlF_6	80
2	ZnS	92
3	Na_3AlF_6	156
4	ZnS	87
5	Na_3AlF_6	149
6	ZnS	84
7	Na_3AlF_6	143
8	ZnS	80
9	Na_3AlF_6	140
10	ZnS	80
11	Na_3AlF_6	143

Table 1 (continued)

Layer Number	material	thickness (nm)
12	ZnS	84
13	Na_3AlF_6	149
14	ZnS	87
15	Na_3AlF_6	156
16	ZnS	92
17	Na_3AlF_6	80

Therefore, this hologram layer 10 is substantially invisible to human eyes, but has such a reflective directivity as to diffract and reflect infrared light projected from a direction opposing the identification label onto a diagonally opposed pair of the sectors 8a through 8h surrounding the light emitting device 6 as illustrated in Figure 2.

When actually identifying the authenticity of the card 1, the card 1 is conveyed to a position where the light emitting device 6 of the light emitting/receiving unit 5 directly opposes the identification label 3. Then, the illuminating light consisting of infrared light is projected upon the identification label 3. The light diffracted and reflected by the identification label 3 is received by some of the sectors 8a through 8h of the light receiving device 8, and the authenticity of the card 1 is determined according to the pattern of the received light. Therefore, even when a forger obtained this card 1 with a fraudulent intent, since the identification label 3 is not visible to the human eyes and is therefore hard to locate, it would be substantially impossible to forge the card, combined with the difficulty in analyzing the reflective directivity of the hologram and the technical difficulties and the prohibitive cost involved in duplicating the hologram.

Obviously, the present invention is not limited to the above embodiment. For instance, the hologram was designed so that the illuminating light may be diffracted and reflected onto a pair selected from the sectors 8a through 8h of the light receiving device 8, but the hologram may also be designed so that the illuminating light may be diffracted and reflected onto four or more of the sectors 8a through 8h. If desired, it is possible to encode specific data or information in the pattern of the diffracted or reflected light, and to use the identification label as a medium for carrying specific information.

Also, in the above embodiment, the identification label 3 was provided on a magnetic card 1 given as an example of information storage card, but it may be provided on valuable papers such as checks, promissory notes and gift certificates, and commercially sold goods in general. In this case, by covering the card 1 with a mask having an opening at a position corresponding to the location of the identification label 3, it is possible to identify the identification label 3 by using a portable hand scanner or the like.

Although the hologram was used in the above embodiment, similar results can be obtained by using dif-

fraction grating on the identification label 3 which is to be affixed onto the card 1:

As described above, according to the optical identification label for identifying an object of the present invention, since the object carries a light reflecting part including a light reflecting layer which transmits visible light but reflects light other than visible light of a prescribed range of wavelength and is provided with a unique reflective directivity that can be identified with optical identification means, and the visible light is therefore not reflected by the reflective layer or, in other words, the reflective layer is made transparent, the identification label will not affect the design of the object, and the freedom in designing the object is increased. Further, since the location of the identification label cannot be easily determined with human eyes, the forgery of the object is made extremely difficult. Thus, the present invention offers a significant advantage.

Although the present invention has been described in terms of a preferred embodiment thereof, it is obvious to a person skilled in the art that various alterations and modifications are possible without departing from the scope of the present invention which is set forth in the appended claims.

Claims

1. An optical identification label (3) comprising:

a hologram forming layer (10a) made of a transparent material and having a hologram or a diffraction grating formed on an underside thereof; and

a light reflecting layer (10b) disposed under the hologram forming layer; the hologram or the diffraction grating being adapted to reflect light with a specific directivity which is identifiable through use of optical identifying means,

characterised in that:

the light reflecting layer is adapted to transmit visible light and to reflect light of any other wavelength.

2. A transparent optical identification label according to claim 1, wherein said reflective layer (10b) consists of alternating layers of at least two kinds of different materials having different refractive indices.

3. A transparent optical identification label according to claim 1, wherein said identification label is affixed to an object as means for preventing an unauthorised duplication of said object.

4. A transparent optical identification label according

to claim 1, wherein the label is arranged such that data is encoded in a geometric pattern of said reflected light.

Patentansprüche

1. Optisches Identifizierungsetikett (3), welches umfaßt:

eine hologrammbildende Schicht (10a) aus einem transparenten Material, die auf der Unterseite ein Hologramm oder ein Beugungsgitter aufweist, und

eine lichtreflektierende Schicht (10b), die unter der das Hologramm bildenden Schicht angeordnet ist,

wobei das Hologramm oder das Beugungsgitter so ausgebildet ist, daß es Licht mit einer bestimmten Richtwirkung reflektiert, die unter Verwendung von optischen Identifizierungsmitteln identifiziert werden kann,

dadurch gekennzeichnet, daß

die lichtreflektierende Schicht so ausgebildet ist, daß sie sichtbares Licht durchläßt und Licht jeder anderen Wellenlänge reflektiert.

2. Transparentes optisches Identifizierungsetikett nach Anspruch 1, worin die Reflexionsschicht (10b) aus alternierenden Schichten von mindestens zwei Arten unterschiedlicher Materialien mit unterschiedlichen Brechungsindizes besteht.

3. Transparentes optisches Identifizierungsetikett nach Anspruch 1, worin das Identifizierungsetikett an einem Objekt angebracht ist, um eine nicht autorisierte Vervielfältigung des Objekts zu verhindern.

4. Transparentes optisches Identifizierungsetikett nach Anspruch 1, worin das Etikett derart angeordnet ist, daß in einem geometrischen Muster des reflektierten Lichts Daten verschlüsselt sind.

Revendications

1. Etiquette (3) d'identification optique comprenant :

une couche (10a) formant un hologramme, constituée en matériau transparent et comportant un hologramme ou un réseau de diffraction formé sur une face inférieure de celle-ci ; et une couche (10b) réfléchissant la lumière disposée sous la couche formant un hologramme ;

l'hologramme ou le réseau de diffraction étant

susceptibles de réfléchir la lumière avec une directivité spécifique qui est identifiable grâce à l'utilisation de moyens d'identification optiques,

caractérisée en ce que : 5

la couche réfléchissant la lumière est susceptible de transmettre la lumière visible et de réfléchir la lumière à n'importe quelle autre longueur d'onde. 10

2. Etiquette transparente d'identification optique selon la revendication 1, dans laquelle la couche réfléchissante (10b) est constituée, en alternance, de couches d'au moins deux types de matériaux différents présentant des indices de réfraction différents. 15
3. Etiquette transparente d'identification optique selon la revendication 1, dans laquelle l'étiquette d'identification est apposée sur un objet comme moyen servant à empêcher une reproduction illicite de l'objet. 20
4. Etiquette transparente d'identification optique selon la revendication 1, dans laquelle l'étiquette est conçue de telle sorte les données sont codées en formant un dessin géométrique de lumière réfléchie. 25

30

35

40

45

50

55

Fig. 1

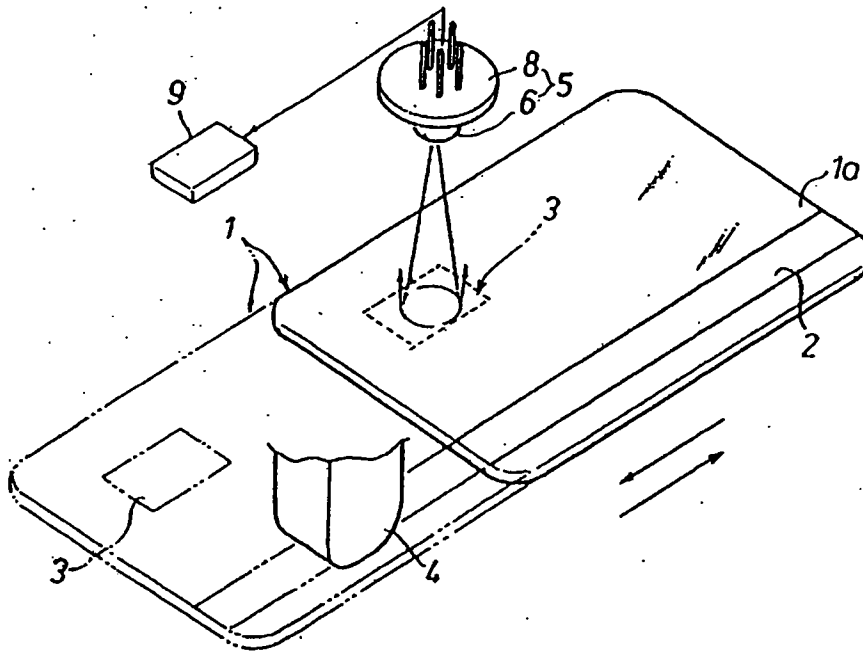

Fig. 2

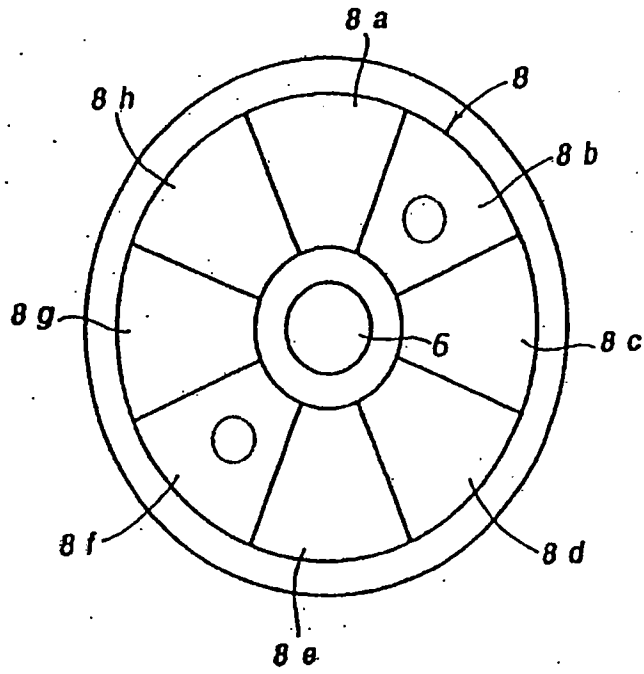

Fig. 3

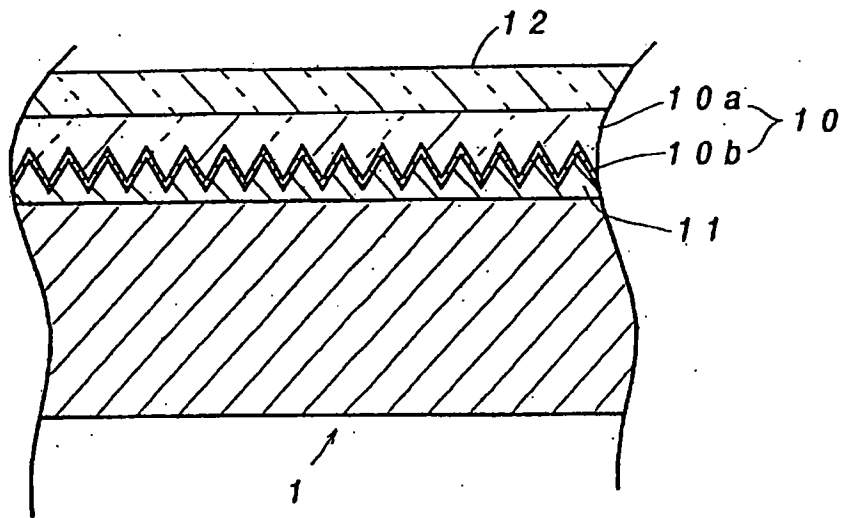

Fig. 4

